

- 教材讨论
– TC第34章

问题1：判定问题和优化问题

- Although P, NP, and NP-complete problems are confined to the realm of decision problems, we can take advantage of a convenient relationship between optimization problems and decision problems.
 - 你怎么理解这句话？
 - 以下这些优化问题对应的判定问题分别是什么？
 - traveling salesperson problem
 - set cover problem
 - knapsack problem
 - 优化问题和对应的判定问题哪个更难？

问题2: P

- 关于P, 你如何理解这几句话:
 - Very few practical problems require time on the order of a high-degree polynomial.
 - For many reasonable models of computation, a problem that can be solved in polynomial time in one model can be solved in polynomial time in another.
 - 特别地, 对于parallel computer, 为什么要强调the number of processors grows **polynomially** with the input size
 - The class of polynomial-time solvable problems has nice closure properties.

问题2: P (续)

- 为什么关于复杂性的讨论会涉及到编码? 你能举个例子吗?
- 如何将编码从复杂性的讨论中隔离出去?
 - Rule out “expensive” encodings.
 - If two encodings e_1 and e_2 of an abstract problem are **polynomially related**, whether the problem is polynomial-time solvable or not is independent of which encoding we use.

问题2: P (续)

- decide in polynomial time和accept in polynomial time的区别是什么?
 - To accept a language, an algorithm need only produce an answer **when provided a string in L**, but to decide a language, it must correctly accept or reject **every string in $\{0, 1\}^*$** .
- 但两者又有以下联系，为什么会有这种联系？
 - $P = \{L \subseteq \{0, 1\}^* : \text{there exists an algorithm } A \text{ that decides } L \text{ in polynomial time}\} .$
 - $P = \{L : L \text{ is accepted by a polynomial-time algorithm}\} .$
- 在模拟接受算法的判定算法中，如果接受算法不停机，判定算法可以在什么时候停下来？

问题3: NP

- 你怎么理解certificate?
- 这些NP问题中的certificate是什么? 如何来验证?
 - longest simple path
 - hamiltonian cycle
 - 3-CNF satisfiability
 - circuit satisfiability
 - formula satisfiability
 - clique problem
 - vertex cover problem
 - traveling salesman problem
 - subset sum problem $\text{SUBSET-SUM} = \{(S, t) : \text{there exists a subset } S' \subseteq S \text{ such that } t = \sum_{s \in S'} s\}$.
 - primality testing
 - http://en.wikipedia.org/wiki/Primality_certificate

问题3: NP (续)

- 和上周相比, 现在你对这些概念是不是更清楚了?
 - 可解 vs. 可验证
 - 确定性 vs. 非确定性
- 你能分别从这两个方面来解释 $P \subseteq NP$ 吗?

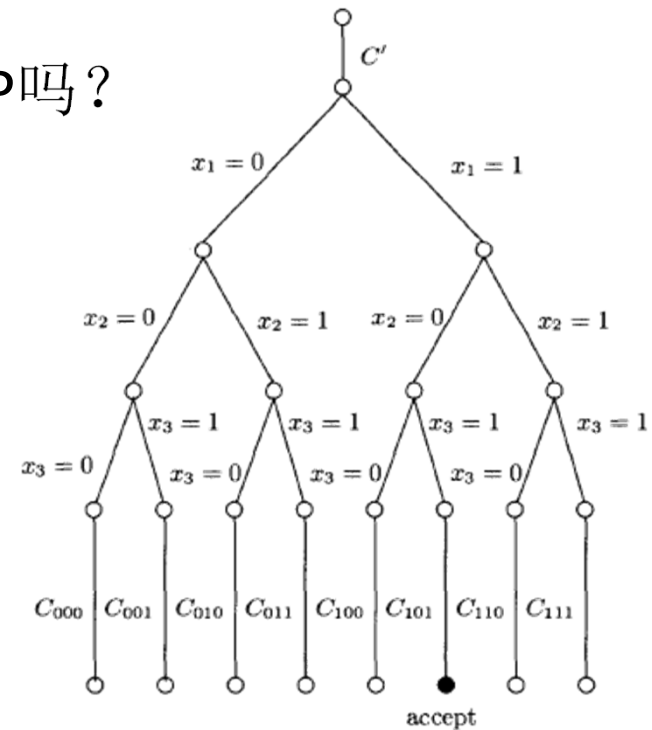

问题4: NPC

- 你怎么理解 L_1 is polynomial-time reducible to L_2 ?

if there exists a polynomial-time computable function $f : \{0, 1\}^* \rightarrow \{0, 1\}^*$ such that for all $x \in \{0, 1\}^*$,

$x \in L_1$ if and only if $f(x) \in L_2$.

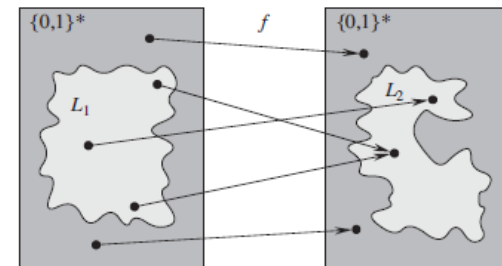

- 作为一种二元关系, \leq_P 具有什么性质?
- 为什么这条引理成立?

Lemma 34.3

If $L_1, L_2 \subseteq \{0, 1\}^*$ are languages such that $L_1 \leq_P L_2$, then $L_2 \in P$ implies $L_1 \in P$.

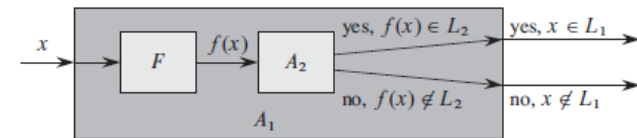

- 如何基于 \leq_P 来定义 NP-hard?

$L' \leq_P L$ for every $L' \in NP$

- NPC是怎么定义的? 为什么这条定理成立?

Theorem 34.4

If any NP-complete problem is polynomial-time solvable, then $P = NP$.

问题4: NPC (续)

- 你理解这条引理的证明了吗?

Lemma 34.6

The circuit-satisfiability problem is NP-hard.

- 如何建立reduction?
 - 电路的内部结构是什么?
 - 电路的输入输出是什么?
- 如何证明它是polynomial-time computable?

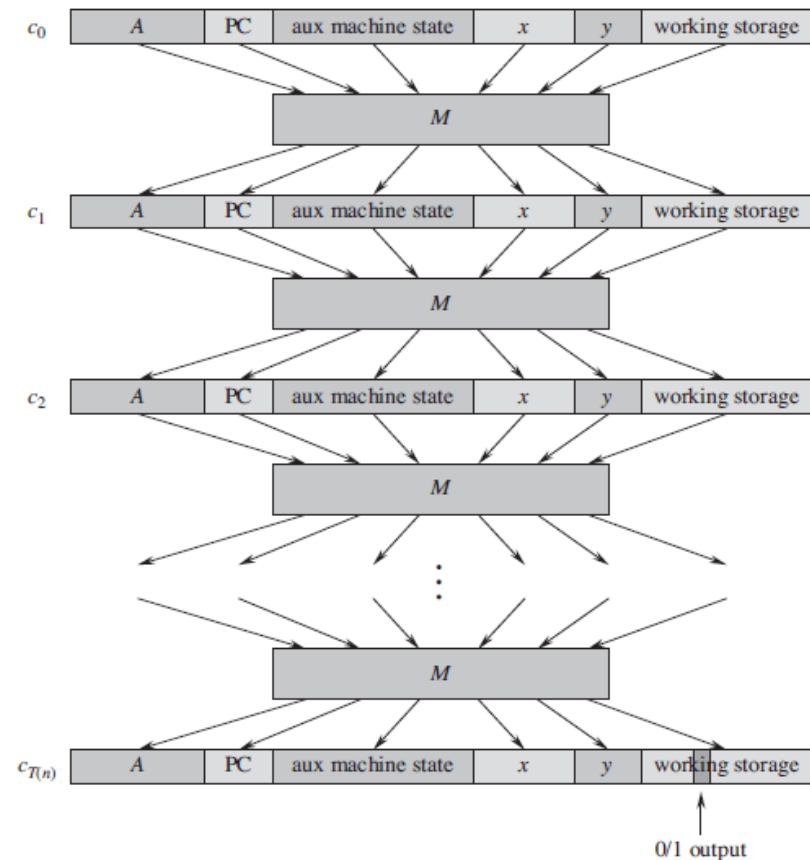

问题4: NPC (续)

- 证明NPC的一般方法是什么?
 1. Prove $L \in \text{NP}$.
 2. Select a known NP-complete language L' .
 3. Describe an algorithm that computes a function f mapping every instance $x \in \{0, 1\}^*$ of L' to an instance $f(x)$ of L .
 4. Prove that the function f satisfies $x \in L'$ if and only if $f(x) \in L$ for all $x \in \{0, 1\}^*$.
 5. Prove that the algorithm computing f runs in polynomial time.

问题4: NPC (续)

- 这张图是什么意思?

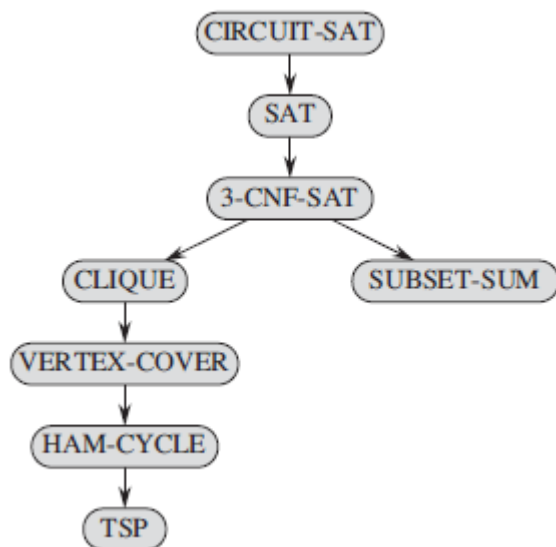

问题4: NPC (续)

- 如何将circuit satisfiability归约到formula satisfiability, 从而证明后者是NP-hard?

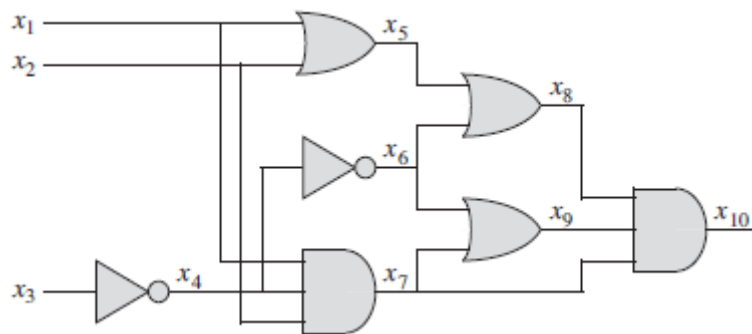

$$\begin{aligned} \phi = & x_{10} \wedge (x_4 \leftrightarrow \neg x_3) \\ & \wedge (x_5 \leftrightarrow (x_1 \vee x_2)) \\ & \wedge (x_6 \leftrightarrow \neg x_4) \\ & \wedge (x_7 \leftrightarrow (x_1 \wedge x_2 \wedge x_4)) \\ & \wedge (x_8 \leftrightarrow (x_5 \vee x_6)) \\ & \wedge (x_9 \leftrightarrow (x_6 \vee x_7)) \\ & \wedge (x_{10} \leftrightarrow (x_7 \wedge x_8 \wedge x_9)). \end{aligned}$$

问题4: NPC (续)

- 如何将 formula satisfiability 归约到 3-CNF satisfiability, 从而证明后者是 NP-hard?

$$\phi = ((x_1 \rightarrow x_2) \vee \neg((\neg x_1 \leftrightarrow x_3) \vee x_4)) \wedge \neg x_2.$$

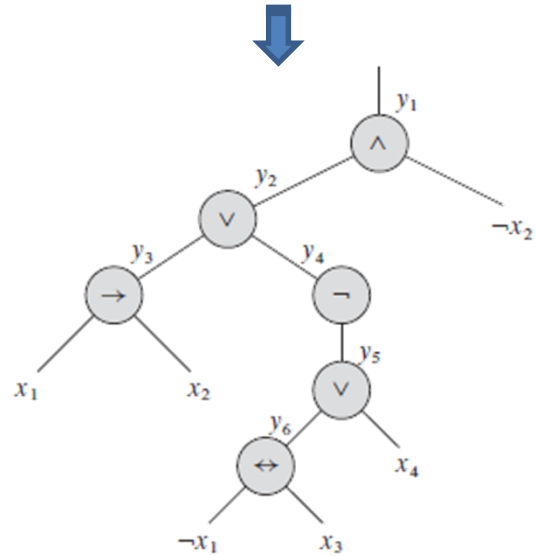

$$\begin{aligned} \phi' = & y_1 \wedge (y_1 \leftrightarrow (y_2 \wedge \neg x_2)) \\ & \wedge (y_2 \leftrightarrow (y_3 \vee y_4)) \\ & \wedge (y_3 \leftrightarrow (x_1 \rightarrow x_2)) \\ & \wedge (y_4 \leftrightarrow \neg y_5) \\ & \wedge (y_5 \leftrightarrow (y_6 \vee x_4)) \\ & \wedge (y_6 \leftrightarrow (\neg x_1 \leftrightarrow x_3)). \end{aligned}$$

y_1	y_2	x_2	$(y_1 \leftrightarrow (y_2 \wedge \neg x_2))$
1	1	1	0
1	1	0	1
1	0	1	0
1	0	0	0
0	1	1	1
0	1	0	0
0	0	1	1
0	0	0	1

$$\begin{aligned} \phi'' = & (\neg y_1 \vee \neg y_2 \vee \neg x_2) \wedge (\neg y_1 \vee y_2 \vee \neg x_2) \\ & \wedge (\neg y_1 \vee y_2 \vee x_2) \wedge (y_1 \vee \neg y_2 \vee x_2), \end{aligned}$$

If C_i has 2 distinct literals, that is, if $C_i = (l_1 \vee l_2)$, where l_1 and l_2 are literals, then include $(l_1 \vee l_2 \vee p) \wedge (l_1 \vee l_2 \vee \neg p)$ as clauses of ϕ''' .

If C_i has just 1 distinct literal l , then include $(l \vee p \vee q) \wedge (l \vee p \vee \neg q) \wedge (l \vee \neg p \vee q) \wedge (l \vee \neg p \vee \neg q)$ as clauses of ϕ''' .

问题4: NPC (续)

- 如何将3-CNF satisfiability归约到clique problem, 从而证明后者是NP-hard?

$$\phi = (x_1 \vee \neg x_2 \vee \neg x_3) \wedge (\neg x_1 \vee x_2 \vee x_3) \wedge (x_1 \vee x_2 \vee x_3)$$



$$C_1 = x_1 \vee \neg x_2 \vee \neg x_3$$

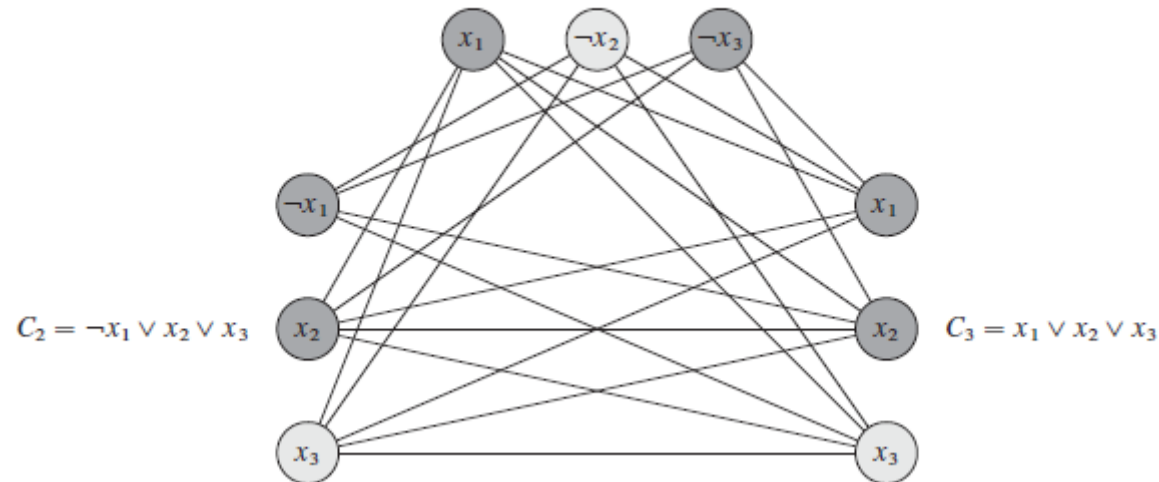

问题4: NPC (续)

- 如何将clique problem归约到vertex cover problem, 从而证明后者是NP-hard?

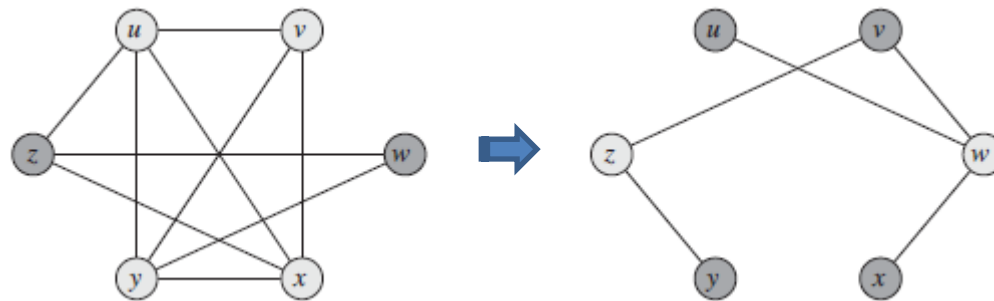

问题4: NPC (续)

- 如何将hamiltonian cycle归约到traverling salesman problem, 从而证明后者是NP-hard?

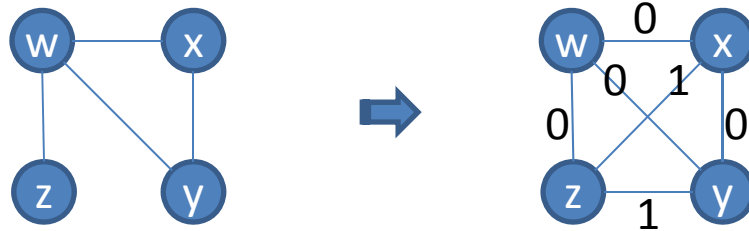

问题4: NPC (续)

- 如何将3-CNF satisfiability归约到subset sum problem, 从而证明后者是NP-hard?

$\phi = C_1 \wedge C_2 \wedge C_3 \wedge C_4$, where $C_1 = (x_1 \vee \neg x_2 \vee \neg x_3)$, $C_2 = (\neg x_1 \vee \neg x_2 \vee \neg x_3)$, $C_3 = (\neg x_1 \vee \neg x_2 \vee x_3)$, and $C_4 = (x_1 \vee x_2 \vee x_3)$.



	x_1	x_2	x_3	C_1	C_2	C_3	C_4
$v_1 =$	1	0	0	1	0	0	1
$v'_1 =$	1	0	0	0	1	1	0
$v_2 =$	0	1	0	0	0	0	1
$v'_2 =$	0	1	0	1	1	1	0
$v_3 =$	0	0	1	0	0	1	1
$v'_3 =$	0	0	1	1	1	0	0
$s_1 =$	0	0	0	1	0	0	0
$s'_1 =$	0	0	0	2	0	0	0
$s_2 =$	0	0	0	0	1	0	0
$s'_2 =$	0	0	0	0	2	0	0
$s_3 =$	0	0	0	0	0	1	0
$s'_3 =$	0	0	0	0	0	2	0
$s_4 =$	0	0	0	0	0	0	1
$s'_4 =$	0	0	0	0	0	0	2
$t =$	1	1	1	4	4	4	4